

opk AIRCRAFT 6

NEUESTE TECHNIK - ELEGANT & EDEL AUF HÖCHSTEM NIVEAU.
NEWEST TECHNOLOGY - ELEGANT & NOBLE AT THE HIGHEST LEVEL.
TECHNOLOGIE DE POINTE - ÉLÉGANTE ET NOBLE À UN SEUL NIVEAU.

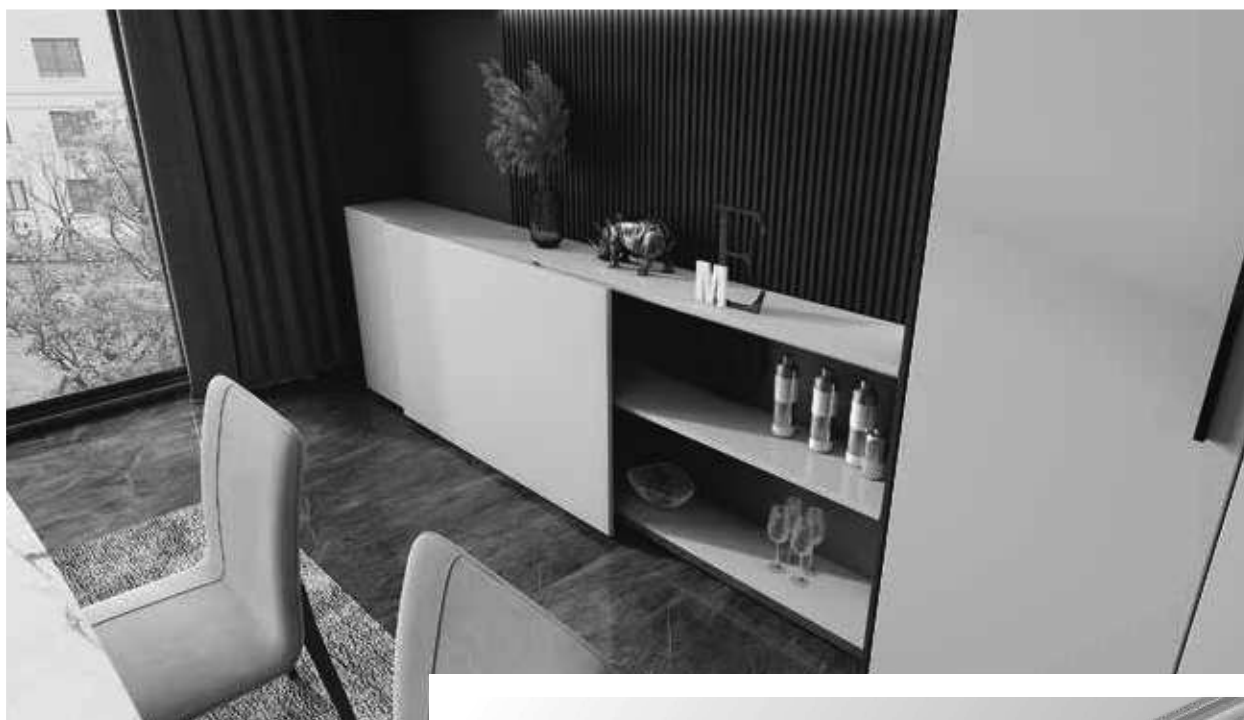

Möbelsysteme
Furniture systems /
Systèmes de meubles

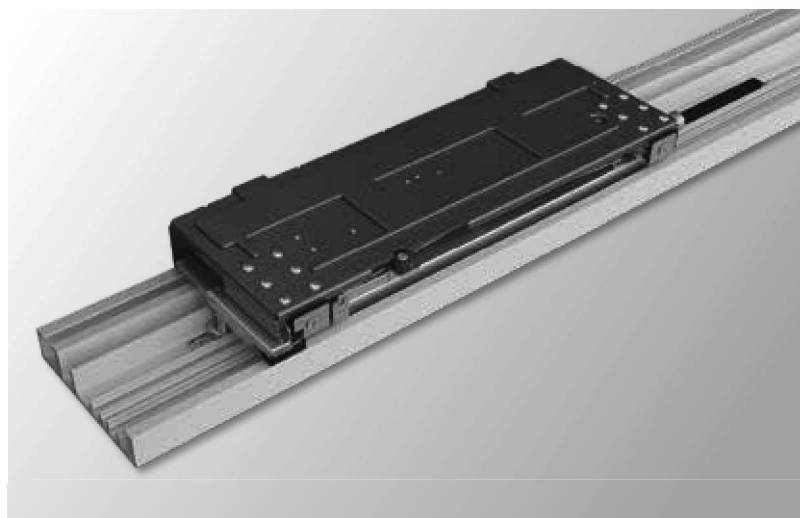
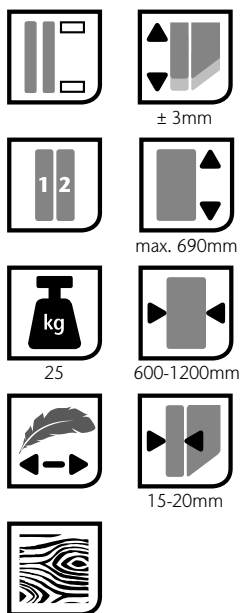

opk Aircraft 6

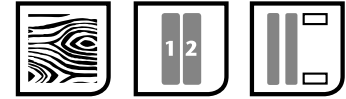

Technische Zeichnung Technical drawing / Plans et schémas

X die Dicke der oberen oder unteren Platte /
X the thickness of the top panel or bottom panel / X l'épaisseur de la plaque supérieure ou inférieure

Türdicke Door thickness / Épaisseur de porte	15-20mm (mit einer Hand / with one hand / À une seule main)
Türbreite Door width / Largeur de porte	600-1200mm
Türhöhe Door height / Hauteur de la porte	≥690mm

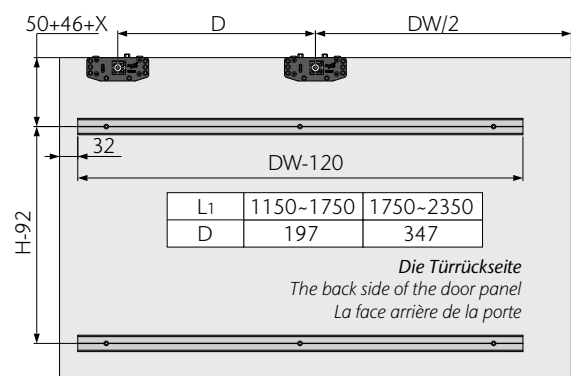
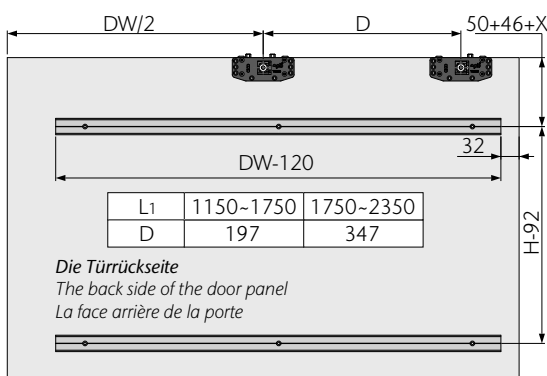
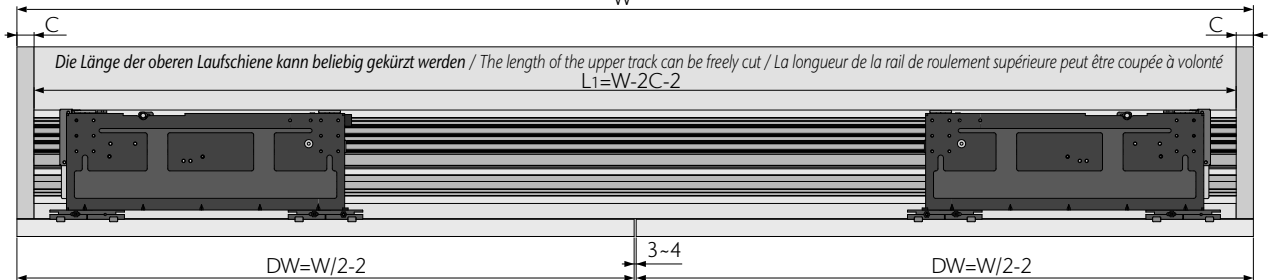
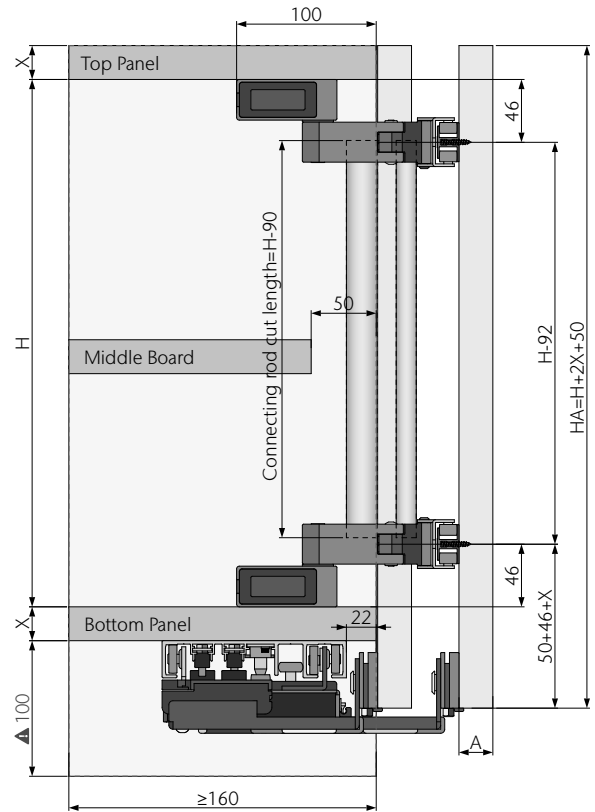
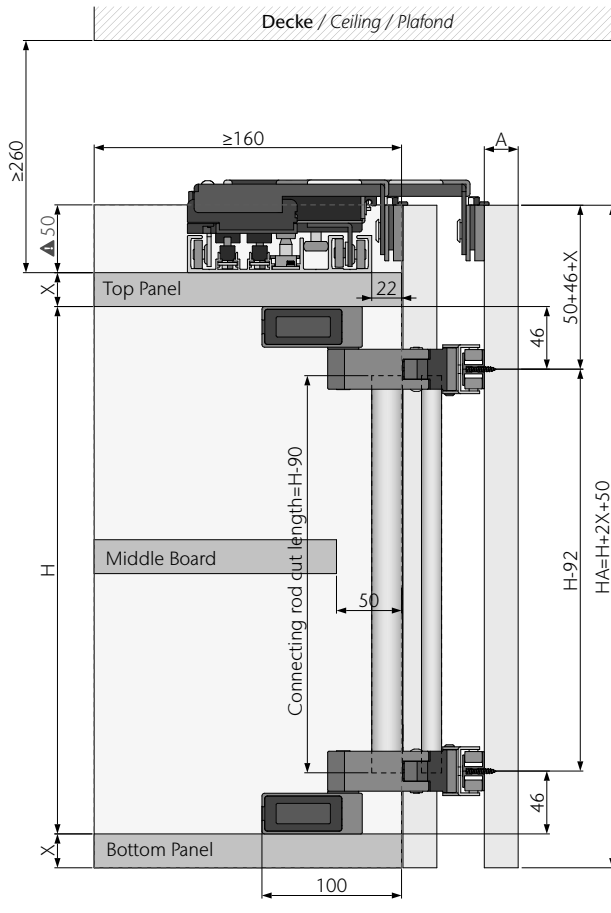

opk Aircraft 6

Complete Set



Konfiguration für 2 Türen

Configuration for 2 doors /
Configuration pour 2 portes

Laufschienen Länge (mm)
Up Track Length /
Longueur de la rail de roulement

Schrankbreite (mm)
cabinet width /
Largeur d'armoire





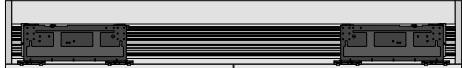

Art.-Nr./No./
N° d'art.

	Laufschienen Länge (mm)	Schrankbreite (mm)	Weight (kg)	Left-Right Movement	Up-Down Movement	Art.-Nr./No./N° d'art.
	1150 - 1750	1200 - 1800	≤15	600 - 900	≤690	01-011-000-001
	1750 - 2350	1800 - 2400	≤25	900 - 1200	≤690	01-011-000-002

Möbelsysteme
Furniture systems /
Systèmes de meubles

Konfiguration für 2 Türen

Configuration for 2 doors / Configuration pour 2 portes

Obere Laufschiene Upper track / Rail de roulement supérieure		1
Türeinsteiler Neuer Typ 2-D New Type 2-D Regulator / Nouveau régulateur de type 2-D		2
Türeinsteiler Neuer Typ 2-D (Links-Rechts-Einstellung) New Type 2-D Regulator (left-right Move) / Nouveau régulateur de type 2-D (Réglage gauche-droite)		2
Fahrgestell Driving Device / Dispositif de conduite		2
Führungsschiene Guiding track / Rail de guidage		4